

OP931

Bi-Directional Insertion Loss & Return Loss Meter

Overview

Insertion Loss & Return Loss Meter

Bi-Directional Insertion Loss (IL) and Return Loss (RL) on fiber optic components are measured fast and accurately with the **OP931 bi-directional**. Return loss is measured using the “no mandrel” method, meaning neither matching gel nor mandrel wraps are required at the far end of the cable. Insertion loss is measured with a continuous and stabilized source of the test set in combination with one of the built-in precision optical power meters. To measure IL/RL in A-B and B-A direction the internal 2x2 optical switch executes a fast bi-directional measurement of IL and RL.



Model OP931 Bi-Directional IL / RL Test Set

Features

Insertion Loss and Return Loss Measurement

- Fully automated, concurrent dual wavelength IL and RL
- Bi-directional operation, measuring total insertion loss, and individual return loss
- IL and RL readings returned simultaneously for all wavelengths
- Multimode return loss to qualify GbE cables
- USB Interface to custom application or included OPL9 application support writing directly to a spreadsheet

Optical Power Measurement

- “State of the Art” fiber optic power meter
- Various detector options for single fiber, MT-RJ and MTP/MPO multifiber connectors
- Automated dual or quad wavelength, bi-directional insertion loss measurement

Return Loss Measurement

- No mandrel wrap nor matching gel
- Singlemode: 10dB to 80dB Return Loss
- Multimode: 10dB to 55dB Return Loss

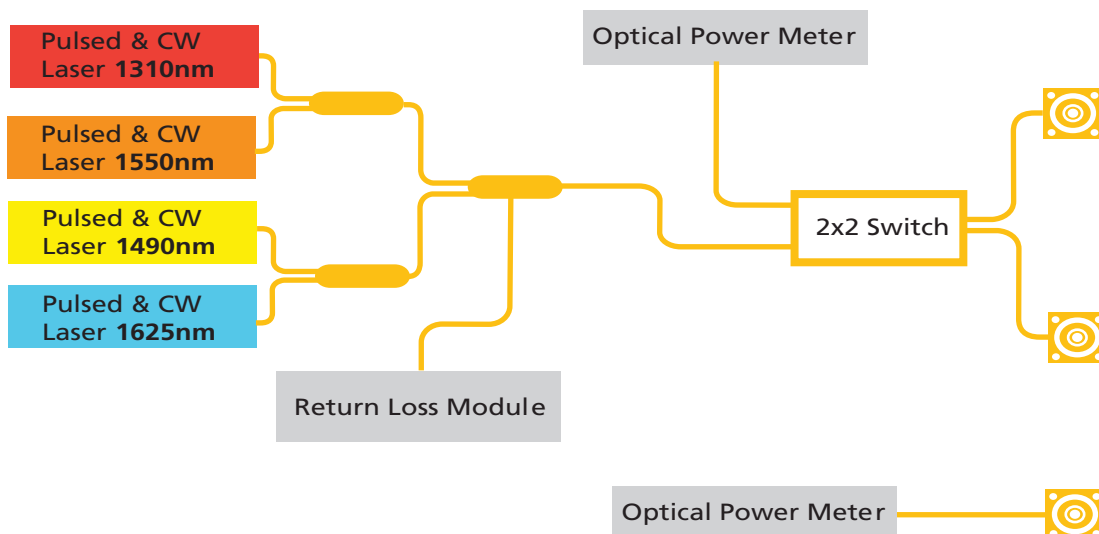

OP931

Bi-Directional Insertion Loss & Return Loss Meter

Specifications

Singlemode Test Sets

	OP930-SM-13/15	OP930-FTTX
Optical Power Meter		
Measurement Range	+10dBm ... -80dBm	
Wavelength Range	830nm ... 1700nm (InGaAs Detector)	
Selectable Wavelength	Standard: 850/1310/1490/1550/1625nm ¹⁾	
Measurement Resolution (Display)	0.01dBm (absolute), 0.001dB (relative)	
Measurement Linearity, Relative Accuracy	0.05dB / 0.02dB ²⁾	
Return Loss Meter		
Source Wavelength	1310nm, 1550nm	1310, 1490, 1550, 1625 nm
Measurement Range	-10dB ... -80dB	-10dB ... -80dB
Absolute Accuracy	+/-1dB (-10dB to -72dB) +/-1.5dB (-72dB..80dB)	
Relative Accuracy, Repeatability	0.1dB (-10dB to -72dB) 0.5dB (>-72dB)	
Distance Range	2.5m ... 2400m	

Multimode Test Set

	OP930-MM-85/13
Optical Power Meter	
Measurement Range	+10dBm ... -80dBm
Wavelength Range	830nm ... 1700nm (InGaAs Detector)
Selectable Wavelength	Standard: 850/1310/1490/1550/1625nm ¹⁾
Measurement Resolution (Display)	0.01dBm (absolute), 0.001dB (relative)
Measurement Linearity, Relative Accuracy	0.05dB / 0.02dB ²⁾
Return Loss Meter	
Source Wavelength	IL: 850nm, 1300nm (qualified EF) RL: 850nm, 1310nm
Measurement Range	-10dB ... -55dB
Absolute Accuracy	+/-1dB (-10dB to -55dB)
Relative Accuracy, Repeatability	0.1dB (-10dB to -52dB) 0.5dB (>-52dB)
Distance Range	2.5m ... 2400m

Performance

Referencing Cycle	< 5 seconds
Referencing Bi-Directional	< 6 seconds
Measurement (Insertion Loss & Return Loss)	< 3 seconds (FTTX: <6 seconds)
Instrument Warm-up	5 minutes

Specifications are subject to change, please confirm specific performance characteristics of the product at the time of ordering.

All specifications are valid within temperature range of 18° C to 24° C unless otherwise noted.

1) NIST traceable calibration at -10dBm.

2) Linearity for loss <5dB and absolute power within -3dBm...-45dBm.