

OP831

Bidirectional Insertion Loss

Instruction Manual

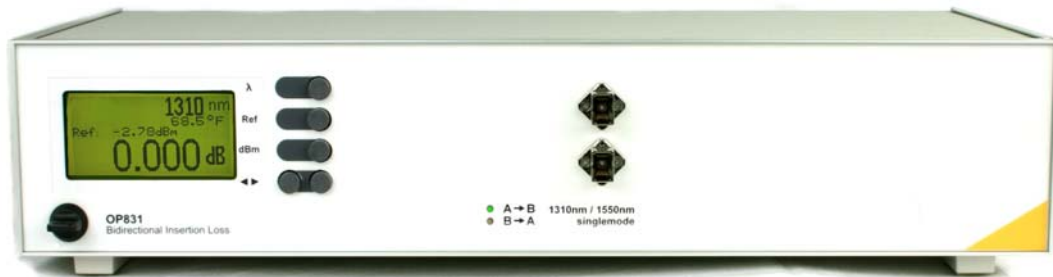

OP831 Bidirectional Insertion Loss

Contacting OptoTest Corporation

Telephone: (805) 987 1700 (8 a.m. to 5 p.m. PST)

Web site: www.optotest.com

E-mail: engineering@optotest.com

Mail: OptoTest Corp.
4750 Calle Quetzal
Camarillo, CA 93012

Notice of Proprietary Rights

The design concepts and engineering details embodied in this manual, which are the property of OptoTest Corporation, are to be maintained in strict confidence. No element or detail of this manual is to be spuriously used or disclosed without the express written permission of OptoTest Corporation. All rights are reserved. No part of this publication may be reproduced, stored in a retrieval system, or transmitted in any form or by any means, electronic, mechanical, photocopying, recording, or otherwise, without prior written permission from OptoTest Corporation.

**COPYRIGHT © 2009 by OptoTest Corp
ALL RIGHTS RESERVED. FIRST EDITION 2004
PRINTED IN THE UNITED STATES OF AMERICA**

MnOP831-RevA1

Table of Contents

OP831 1	
Bidirectional Insertion Loss	1
Instruction Manual	1
Table of Contents	3
Overview	4
Principle of Operation	4
Multifiber Bidirectional Operation	4
Initial Preparation	5
Unpacking and Inspection	5
Damaged In Shipment	5
Standard Contents	5
Specifications	6
OP831-13/15, OP831-850, OP831-1300, OP831-85/13	6
Definition of Specifications	7
Dynamic Range	7
Linearity	7
Calibration Wavelength	7
Calibration Traceability	7
Spectral Responsivity	7
Absolute Accuracy	8
Number of readings/sec	8
Channel Performance	8
Warm-up Time	8
Recommended Recalibration Period	9
Fiber Compatibility	9
Environmental	9
Frontpanel Operation	10
Display 12	
OPM Mode – Power meter mode	12
Bidirectional Insertion Loss	12
Bidirectional Reference	13
Mode Indicator, Bidirectional Indicator, Reference Indicator	13
Wavelength	13
Absolute Power	13
Relative Power	13
Internal Temperature	13
Measurement Instructions	14
Reference	14
Insertion Loss Measurement in A-B Direction and B-A direction	15
USB Control of the OP831	16
Command Summary	16
Warranty Information	17

Overview

The OP831 offers an economical approach for bidirectional insertion loss measurements for either singlemode cables or multimode cables. For the multimode testing the OP831 is equipped with a 850nm LED, a 1300nm LED or a switched 850nm/1300nm dual LED source. The source for the singlemode configuration consists of a dual wavelength laser with 1310nm and 1550nm wavelengths. For all models the power meter is equipped with a fiber terminated InGaAs detector. The internal 2x2 switch routes the light in either A-B direction or B-A direction.

The OP831 also can be combined with a 2xN optical switch for the testing of bidirectional insertion loss on multifiber cables, cables harnesses or qualification testing on a series of cables.

Principle of Operation

Single Cable Bidirectional Operation

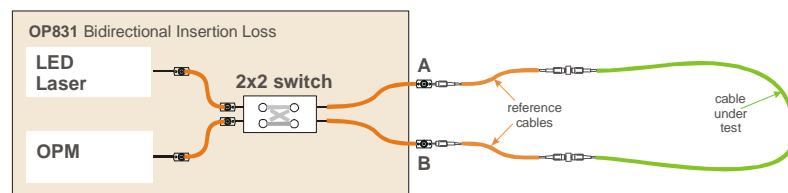

Multifiber Bidirectional Operation

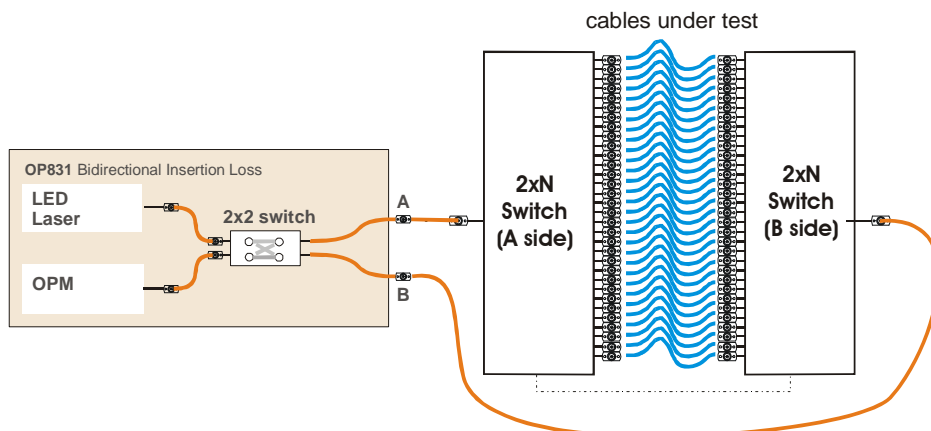

Initial Preparation

Unpacking and Inspection

The unit was carefully inspected, mechanically, electrically and optically before shipment. When received, the shipping carton should contain the items listed in *Standard Contents*. Account for and inspect each item. In the event of a damaged instrument, write or call OptoTest Corp, California. Please retain the shipping container in case re-shipment is required for any reason.

Damaged In Shipment

All instruments are shipped F.O.B. Newbury Park when ordered from OptoTest. If you receive a damaged instrument you should:

1. Report the damage to your shipper immediately.
2. Inform OptoTest Corporation.
3. Save all shipping cartons.

Failure to follow this procedure may affect your claim for compensation.

Standard Contents

1. Model OP831 Bidirectional Insertion Loss
2. Power Cord (U.S. Shipments only)
3. USB A-B cable
4. Certificate of Calibration and if requested the Metrology Report
5. Instruction Manual(s)
6. CD with applicable software and documentation

Specifications

OP831-13/15, OP831-850, OP831-1300, OP831-85/13

	Specifications	
Models	OP831-SM-13/15 OP831-SM-1310 OP831-SM-1550	OP831-MM-85/13 OP831-MM-850 OP831-MM-1300
Power Meter Operation (B-Port)		
Measurement Range	+3 to -80dBm	
Measurement Linearity	+/- 0.05dB (+0dBm to -65dBm)	
Wavelength Dependency	see <i>Spectral Responsivity</i>	
Calibration Wavelength⁽¹⁾	850nm, 980nm, 1300nm, 1310nm, 1480nm 1550nm	
Calibration Traceability	U.S. N.I.S.T.	
Absolute Accuracy	±0.25 dB at calibration conditions for all NIST traceable wavelengths	
Stability⁽²⁾	< ±0.02 dB (3dBm to -65dBm)	
Resolution	0.001 dB Linear: 0.001nW, µW, mW ⁽⁴⁾	
Recommended Calibration Period	12 months	
Settling Time (auto-range from dark to max. power.)	0.2 seconds (0dBm to -80dBm)	
Number of readings/sec. (in remote mode)	≥ 10 readings per second	
Measurement Performance	Internal sampling interval approx. 35msec	
Measurement Modes	dBm, dB	
Optical Connector Interface	fixed bulkhead interface, FC/PC, SC/PC, ST/PC (others available)	
	PC polish angle polish	PC polish only
Fiber Compatibility	9/125 (SMF-28)	62.5/125 GI multimode
Bidirectional Operation		
Source Wavelength	1310nm, 1550nm or both	850nm, 1300nm, or both
Source Type	FP Laser	LED
Output Power	typical -3dBm	typical -10dBm
A-B Operation	Source output on upper port, power meter input on lower port	
B-A Operation	Source output on lower port, power meter input on upper port	
A-B, B-A Switching time	0.2sec (includes settling of power meter)	
Source Switching Time	0.1sec	0.2sec
Referencing Cycle	<5 sec	

⁽¹⁾ NIST traceable calibration at -10dBm, continuous wave

⁽²⁾ Within specified ambient environmental temperature of 20°C to 25°C, stable within +/- 2°C

⁽³⁾ Measured at wavelength of 1480nm

OP831 Bidirectional Insertion Loss

Mainframe	
Power Supply	90VAC .. 264VAC 47Hz to 63Hz 0.7Amps(115VAC) 0.4Amps(230VAC) Fuse: T1A, 250V
Warm-up time	5-15 minutes
Environmental: Operating temp. Storage temp: Humidity	0°C to +50°C -15°C to +70°C 0 - 95% RH (non-condensing)
Dimensions	19" Rack Standard (16.8 x 3.8 x 10 in.)
Shipping dimensions	14" x 12" x 21"
Weight	6lbs
Shipping weight	12lbs

Definition of Specifications

Dynamic Range

The dynamic range spans from the maximal power level the instrument can measure without major saturation to the detector to the minimal power level where the thermal noise of the detector becomes greater than the current produced by the incident light. For accurate power measurements it is NOT recommended to measure power levels at either end of the dynamic range. (see Linearity)

Linearity

Photodetectors are, by nature, very linear over a wide range of optical input powers, but the power meter electronics can affect the overall system linearity. The power meter linearity is characterized and specified to know the measurement accuracy and linearity over the full dynamic range. For accurate insertion loss measurements only power levels that fall within the range with the best linearity (+/-0.05dB) should be measured.

Calibration Wavelength

The calibration wavelengths are the *nominal* wavelengths of the instruments calibration points. The exact wavelength of each particular calibration is stated in the *certificate of calibration*.

Calibration Traceability

The detector's absolute calibration data is directly traceable to N.I.S.T. at the specified calibration wavelength and the specified power level, usually -10dBm.

Spectral Responsivity

Depending on the detector type, InGaAs (Indium Gallium Arsenide) or Silicon the spectral responsivity, the efficiency of the detector to convert optical power into electrical current changes with wavelength.

OP831 Bidirectional Insertion Loss

Responsivity of InGaAs Detectors

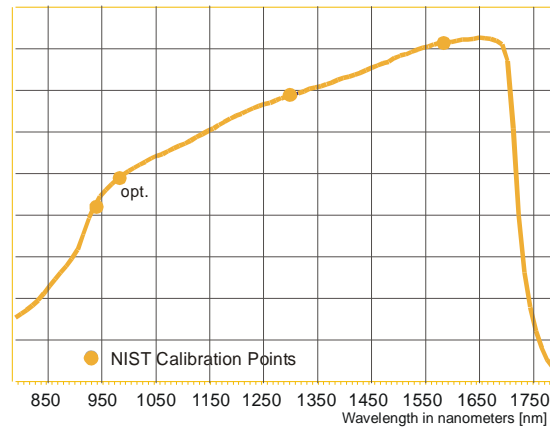

Responsivity of Silicon Detectors

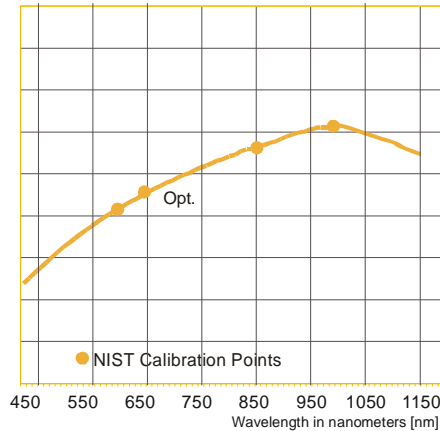

Absolute Accuracy

The absolute accuracy specification includes the total measurement uncertainties involved in the calibration process including the transfer of the absolute power standard from N.I.S.T.

Number of readings/sec

Although the USB interface can handle a data rate of up to 12 Mbit/sec the instrument responds to requests for measurement data not faster than this parameter.

Channel Performance

The power meter circuit converts and digitizes the optical power level with the given sampling interval. Changes in light levels such as modulation will be averaged within that sampling interval.

Warm-up Time

The optical power meters in general do not need any warm-up time unless the instrument has to acclimate to a changing environment. In order to calibrate the instrument or to perform stable measurement the instrument should be acclimated for 15 minutes for each 5°C of temperature differential. For example if the instrument was stored at 18°C and brought into an environment of 28°C the instrument should allowed to warm-up for 30 minutes.

OP831 Bidirectional Insertion Loss

Recommended Recalibration Period

This is the recommended time period for re-calibration in order to maintain accuracy specifications. The recommendation is made based on statistics on detector aging; however it is up to the metrology policies and procedures within each company to define the calibration cycles on optical power meters.

Fiber Compatibility

The amount of aerial coverage of the detector, the portion of the light emitted from the fiber being measured, depends on the mechanical features of the optical interface, the active area of the detector and the numerical aperture (NA) of the fiber. A fiber with a large NA, for example 100/140 multimode fiber, might not under fill a small area detector hence the absolute power reading will be less than actual.

Environmental

Operating Temperature: This is the temperature range in which the instrument will conform to the specifications after the specified warm up time.

Storage Temperature: This is the temperature range at which the instrument can be stored with the power off, without any damage or any loss of specification to the instrument. It is required that the instrument be brought back to within the operating temperature range before it is turned on.

Humidity: The relative non-condensing humidity levels allowed in the operating temperature range.

Frontpanel Operation

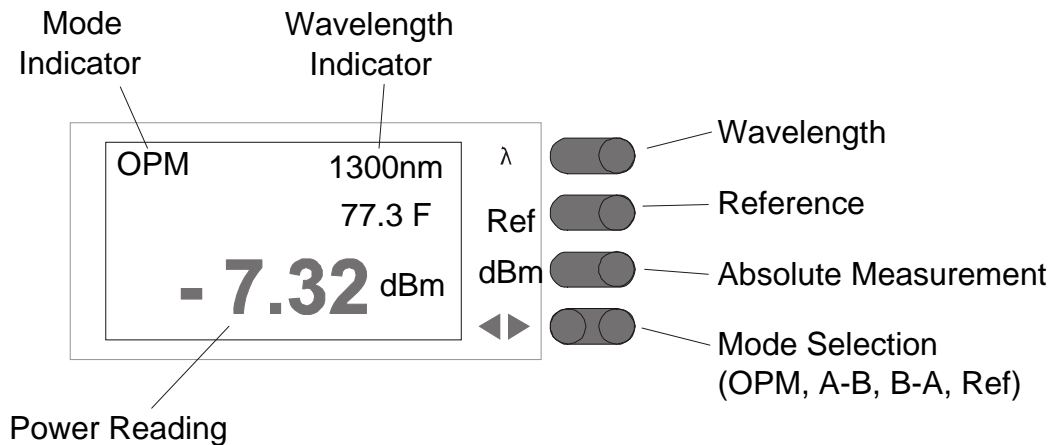

Wavelength

The wavelength button toggles through the available calibration wavelength and source selection depending on the mode of the instrument.

OPM Mode: The measurement wavelengths for the OP831 are 850nm, 1300nm, 1310nm, 1480nm, and 1550nm unless otherwise noted.

A-B, B-A Mode: In bidirectional measurement mode the wavelength button toggles the source wavelength concurrently with the power meter calibration wavelength. For OP831 with a single wavelength source there is no wavelength to be selected, for dual wavelength implementations the wavelength selection is 850nm & 1300nm for multimode, and 1310nm & 1550nm for single mode.

Ref Mode: no function

Reference

For OPM, A-B, B-A modes.

The **Ref** button switches the power meter into relative measurement mode. At the same time it stores the current absolute power reading at the current wavelength as the reference. The reference power is displayed above the relative power reading (see illustration of Display). If the instrument is already in relative measurement mode pressing the **Ref** button stores the

OP831 Bidirectional Insertion Loss

current power level as the new reference. For each wavelength and for each direction a reference reading can be stored.

For Ref mode:

Pressing the **Ref** button in *Ref mode* executes a reference sequence. For single wavelength devices this involves taking the reference in A-B mode and B-A mode, for dual wavelength instruments this involves taking the reference in A-B mode and B-A mode for the first wavelength, then repeats the same for the second wavelength. The referencing cycle can take up to 5 seconds.



Absolute Measurement

For modes: OPM, A-B, B-A:

The **dBm** button switches the power meter into absolute measurement mode.



Mode Selection

The mode selection switches between the following modes:

OPM Optical Power Meter

The OP831 operates as a standard optical power meter measuring absolute or relative power. In this mode the **dBm** button switches the instrument into absolute mode. The **Ref** button switches the instrument to relative mode (also dB mode on other instruments).

A-B Bidirectional

In A-B the upper optical port is the source output and the lower optical port is the power meter input. In this mode the **dBm** button doesn't have a function. The **Ref** button takes the reference measurement. Note that the reference is taken only for the selected wavelength. The absolute reference power is reflected in the Reference Indicator. After taking a reference the instrument continuously measures the insertion loss in the A-B direction.

B-A Bidirectional

In B-A the upper optical port is the source output and the lower optical port is the power meter input. In this mode the **dBm** button doesn't have a function. The **Ref** button takes the reference measurement. Note that the reference is taken only for the selected wavelength. The absolute reference power is reflected in the Reference Indicator. After taking a reference the instrument continuously measures the insertion loss in the B-A direction.

Display

Depending on the selected mode the display shows different measurement parameters and results.

OPM Mode – Power meter mode

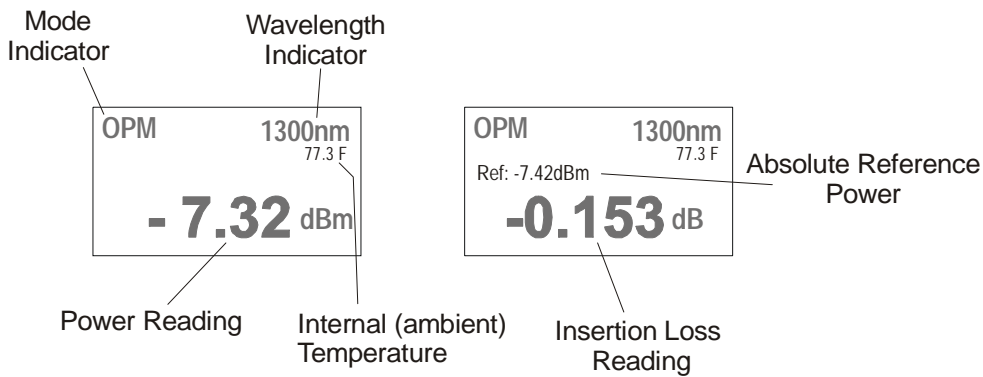

Bidirectional Insertion Loss

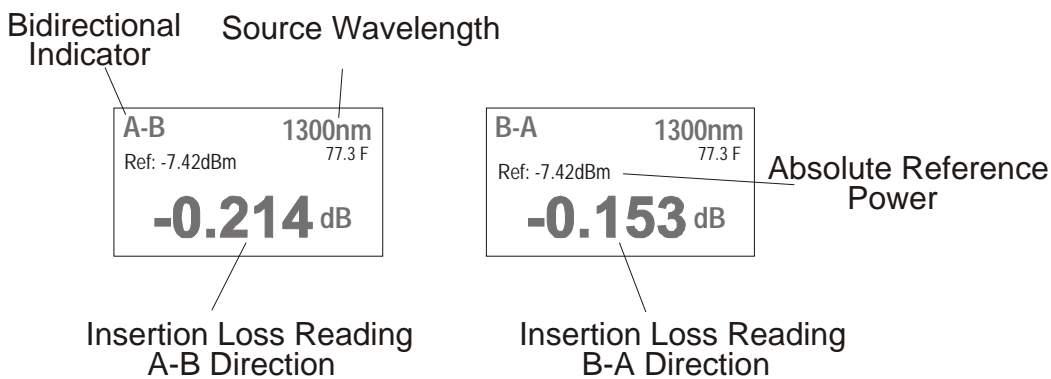

Bidirectional Reference

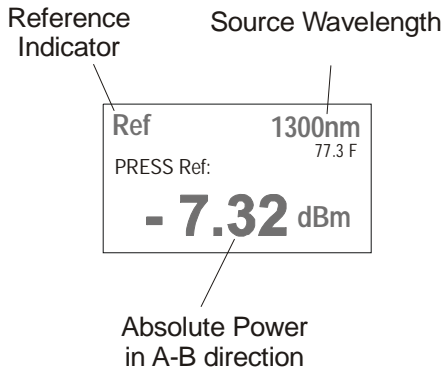

Mode Indicator, Bidirectional Indicator, Reference Indicator

Shows the current selected mode: OPM, A-B, B-A, Ref

Wavelength

Displays the currently selected calibration wavelength of the source wavelength used to measure in bidirectional mode. Typical wavelengths are as follows:

OPM Mode	850nm, 980nm, 1300nm, 1310m, 1480nm, 1550nm
A-B, B-A	Multimode: 850nm, 1300nm, Singlemode: 1310nm, 1550nm

Absolute Power

The absolute power is displayed in dBm.

Relative Power

The relative power is displayed in dB. It is the difference between the reference power at the corresponding wavelength and the measured absolute power.

Internal Temperature

The internal, ambient temperature is displayed in either °F (Fahrenheit) or °C (Celsius), that selection is performed with a USB command.

Measurement Instructions

For the manual measurement of unidirectional or bidirectional insertion loss, follow these instructions:

Reference

Connect two reference cables as shown, please note that the use of quality reference cables is essential, a high loss from the reference connection will grossly dilute the measurement result of the actual cable.

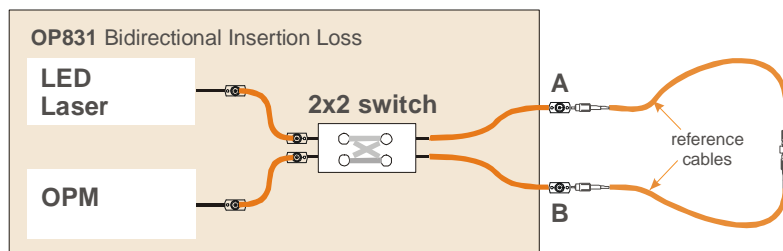

Switch the instrument to Ref mode and press the Ref button to execute the referencing cycle. The instrument will cycle through all the wavelengths in A-B and B-A direction, takes the absolute power reading and stores them. The instrument will end up in A-B mode at the end of this process.

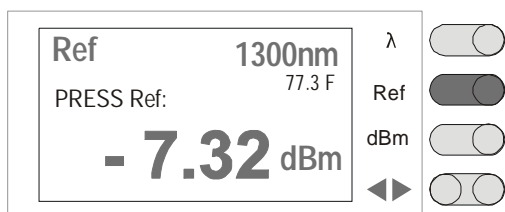

Insertion Loss Measurement in A-B Direction and B-A direction

Connect the cable to be tested as shown:

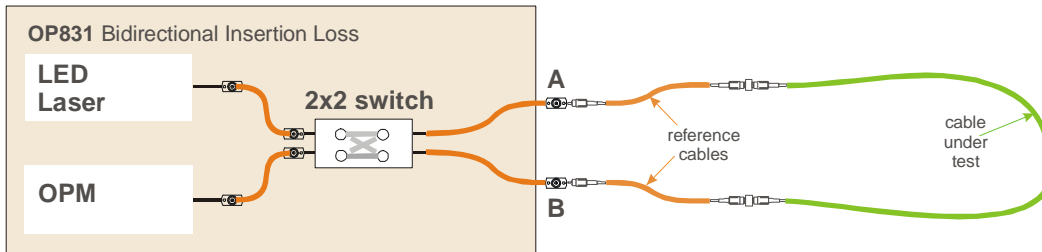

The display of the A-B measurement will show the insertion loss of the connected cable. To measure and display the insertion loss at the other wavelength (if available) use the lambda button and switch the wavelength.

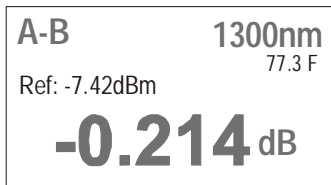

To measure the insertion loss in the other direction use the mode button to switch to B-A mode. The display of the B-A measurement will show the insertion loss of the connected cable. To measure and display the insertion loss at the other wavelength (if available) use the wavelength button and switch the wavelength.

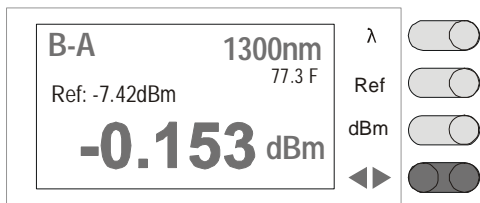

Others cables can be measured by simply connecting them to the two reference cables as shown above. There is no need for a repeated reference cycle unless the reference cables have been changed. If a long time (hours) has elapsed since the last reference cycle or the measurement procedure requires a frequent referencing.

Please note that cleaning the connectors before each measurement should be standard practice.

USB Control of the OP831

The OP831 can be controlled via the USB bus. The following commands are available via the OP710.DLL to communicate with the instrument through a program.

Command Summary

NOTE: For a detailed and complete description of the OP831.DLL function calls please consult the OP831.DLL Description on the Applications and Driver CD or visit the support section of www.optotest.com.

InitDLL	Initializes the OP710.DLL	
GetDLLStatus		Returns the status of the last library call.
GetUSBDeviceCount		Returns the number of OptoTest devices connected to the USB bus.
GetTemperature		Returns the ambient temperature either Celsius or Fahrenheit
ReadPower	Returns the power reading of the current direction.	
SetWavelength		Sets the calibration wavelength.
Backlight	Lights or dims the backlight of the instrument.	

Warranty Information

OptoTest Corp. warrants this product to be free from defects in material and workmanship for a period of one year from date of shipment. During the warranty period we will, at our option, either repair or replace any product that proves to be defective. To exercise this warranty contact OptoTest Corp. Headquarters. You will be given prompt assistance and return instructions. Repairs will be made and the instrument returned, transportation prepaid. Repaired products are warranted for the balance of the original warranty period, or at least 90 days.

NOTE: Do not send instruments for any reason without contacting OptoTest headquarters first.